

LFM11 Series

Differential pressure transmitter

LEFOO

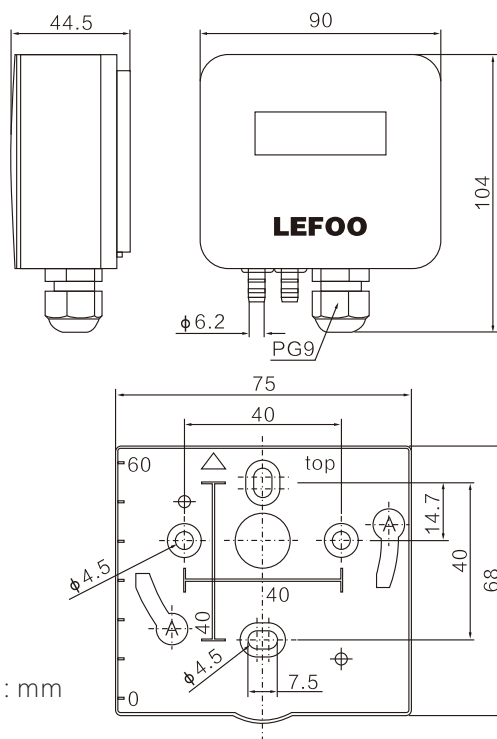

Dimension in : mm

Low Differential Pressure Transmitter LFM110/LFM112 are engineered for building automation in the HVAC/R industry , pressure and flow monitoring, and low differential pressure test in industry application.

LFM11 Series Order Ref NO

LFM110 - N - A - C

A B C D

A Span	B Display	C Output	D Accuracy
0=-1000~1000Pa	O=with display	A=4~20mA,0-5/10VDC	±1.0%FS
2=-10000~10000Pa	N=without display	B=4~20mA(2-wire)	
6=-100~100Pa		C=0~10VDC(3-wire)	
		D=0~5VDC(3-wire)	

Specification

General	Value	
Accuracy	±1.0%FS	
Unit	Pa,mmH2O,mbar,inWG,mmHG,daPa,hPa	
Output signal	0~5/10VDC and 4~20mA simultaneous output, 4~20mA 2-wire 0~5VDC 3-wire,0~10VDC 3-wire	
Supply Voltage	16~30VDC/16~30VAC	
Power Supply	1.5W	
Response time	20ms,0.5s,1s,2s	
Resolution	LFM110:1Pa,1mmH2O,0.01mbar,0.04inWG,0.007mmHG,0.1daPa,0.001kPa LFM112:0.01hPa LFM116:0.1Pa,0.01mmH2O,0.001mbar,0.01daPa,0.001hPa	
Zero Point adjustment	Automatic with autozero element or with push button	
Measuring unit	Air or neutral gas	
Operation Temperature	-10~60°C	
Storage Temperature	-10~70°C	
Over pressure capacity	Range	
	-1000~1000Pa	-15000~15000Pa
	-10000~10000Pa	-150000~150000Pa
	-100~100Pa	-4500~4500Pa

Conversion:1in W.C.=249Pa 1MPa=100Pa