

# LF55T Temperature Switch

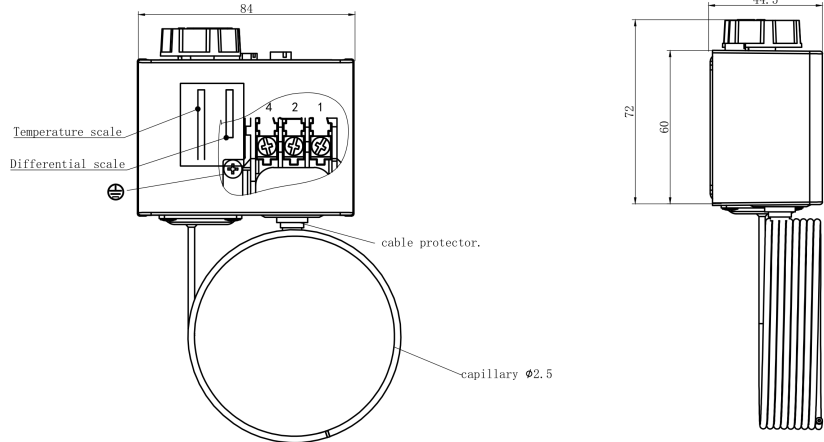

The LF55T Temperature control switch which mainly controls the temperature control of the greenhouse.

# LEFOO



Attention : 1. Pls remove the temperature adjustment knob and fixing plate before adjust the temperature.  
2. Pls fix the temperature adjustment knob and fixing plate after finishing the temperature adjustment.

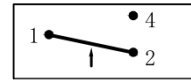
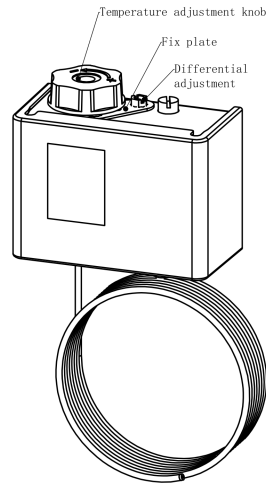

Attention : 1. Low temperature protection, pls connect wire 1-4  
2. High temperature protection, connect wire 1-2

Dimension in:mm

Temperature Range	Differential pressure range	Setting temperature
-30°C-15°C	2-10	-7/-9
0°C-40°C	3-10	20°C/15
-50°C-0°C	3-10	-25/-28
50°C-100°C	5-15°C	75°C/65
20-60°C	3-10°C	40°C/35

## Specification

Modle	LF55T
Contact agreement	SPDT
Electrical rating	AC15:10A,240V;DC12W,220V; Contact resistance≤500mΩ
Contact material	static contact: fine silver, movable contact:Silver plated
Breakdown voltage	one min at 2000v no breakdown
Protection grade	IP 30 (IP44 when with bracket and cover)
Environment Temp	-25°C/+65°C
Media Temp	-40°C/+120°C
Mechanical lifespan	100k times
Electrical lifespan	30K times
Max installation torque	2 N/M
Capillary	Φ2.5, The minimum contacting length of the capillary and environment: 0.43m,Capillary length can be customized
Cable connection	Φ 6-14 cable