

LF37 Liquid level pressure switch

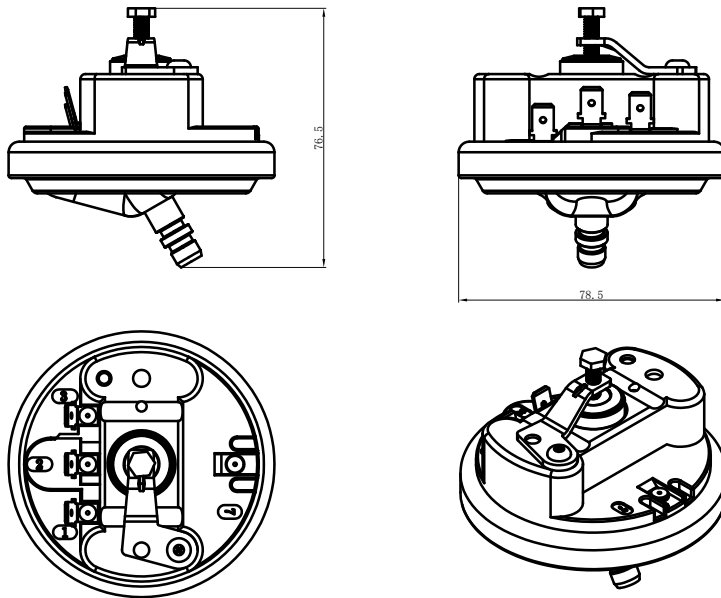

Dimension in:mm



LF37 Order Ref NO

LF37 - 1 1 1 -4.5"-6"H₂O

A B C Pressure setting:cut in :6"H₂O ; cut off :4.5"H₂O

LF37 diaphragm pressure switch is available for various sumps, effluent, and sewage application to control the liquid level. Various switch settings are available for to turn-on or turn-off the pump. The diaphragm pressure sensing design make it more reliable than traditional float ball mechanism. Port connection design make it can sense the pressure without immersing the liquid directly.

Number	Connection Type	Contact Arrangement	Enclosure
0	/	/	none enclosure
1	A Diaphragm	B SPDT	C with enclosure
2	Φ6mm for tube	SPST-NO	/
3	1/4NPT	SPST-NC	/

Specification

Model	LF37
Media	Air,water or other non-hazardous liquid
Basic function	Diaphragm Pressure switch operation:provide water level signals to appliance control,level value can be set on customer request
Pressure Range liquid level Range	2~60 in W.C.
Proof Pressure	5psi
Contact Type	SPDT,SPST-NC/NO
Electrical Rating	12/13.8A,125VAC 10A,250VAC 1/2HP;125/250VAC 3/4HP;125/250VAC
Ambition Temperature	40℃
Terminal	6.3×0.8 blade