

LF17-W

Pump pressure switch

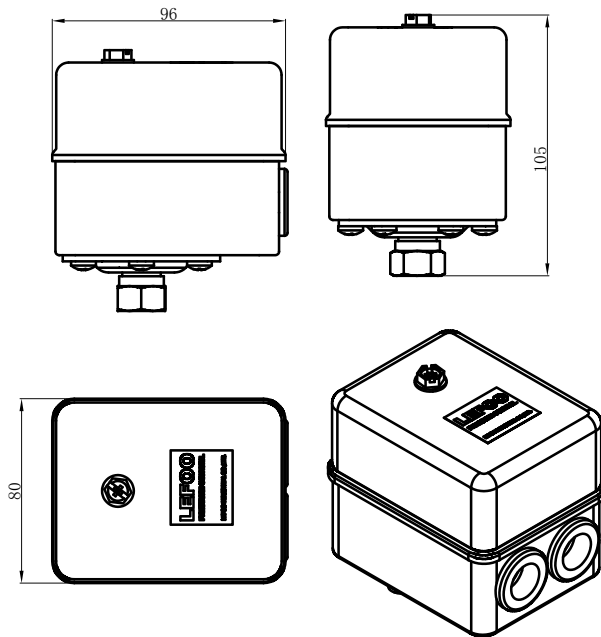

LEFOO



Dimension in:mm

The rugged LF17 pressure switch is designed for the demanding requirements of larger, heavy duty commercial water pump system.

LF17-W Order Ref NO

LF17-W -1 1 1 -80-100psi

A B C Pressure setting:Cut in 80psi

Cut off 100psi

Number	Connection Type		Connection Size
1	A single port	B female	C 1/4NPT
2	/	male	3/8NPT
3	/	/	R1/4
4	/	/	R3/8
5	/	/	G1/4
6	/	/	G3/8

Specification

Model	Media	Operating Pressure Range	Factory Setting	Differential	Electrical Rating	Contact Arrangement	Connection
LF17-W	Water	40-250psi	80-100psi	20-60psi	120VAC, 24A 240VAC, 20A	NC	G,NPT1/4, 3/8 Male or Female
	Water	14-100psi	40-70psi	14-50psi			
LF17-W5	Water	15-60psi	30-45psi	7-20psi			

Conversion:1kgf/cm²=14.2psi 1bar=14.5psi